

Expanding horizons

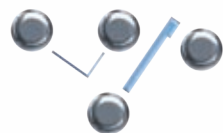

DiGiCo *EX-007*

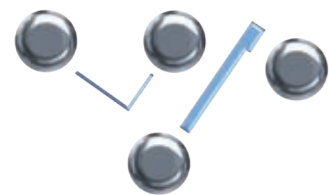



DiGiCo EX-007



Whilst other manufacturers are just waking up to the idea that a console needs to be an extremely versatile, networkable and expandable piece of equipment, DiGiCo is well ahead of the game, already having developed a raft of products that have these capabilities either built in to the core unit, or available through a range of remote control and expander units.

The latest such product is the EX-007, designed to substantially increase the number of available faders and the number of channels controllable at any one time on an SD7 - and from a distance of up to 100 metres via a cost-effective Cat5 cable connection.

It is possible to augment an SD7 with two EX-007s, each acting as a control panel to provide 24 faders and two additional touch screens, as well as

metering and other standard functions, transforming the already impressive SD7 into a 100-fader mixing console.

The EX-007 networks to the SD7, has its own power supply and its own PC.

"The EX-007 has many applications," says DiGiCo managing director, James Gordon. "For touring, there's the obvious advantage of more faders and

the ability to control everything that's on the main desk from multiple locations - ideal for shows where a number of mix positions are required because of a multi-stage set up.

"For fixed installations, the EX-007 can be used as a remote surface and, because it can be situated up to 100m away and controls both inputs and outputs, you can have your SD7 in the control room at the back of the theatre and your EX-007 in the auditorium. Also, the EX-007 is substantially smaller than the SD7, which has the added advantage of freeing up more seats and consequently means more revenue for the theatre."

The EX-007 comes with the assurance that it will work with all existing SD7 and SD-7T consoles, as well as future products in the SD-7 family. So whether you are simply adding extra faders, or require a remote surface in a separate location, the EX-007 opens up a world of opportunities both now and into the future.



www.digico.org

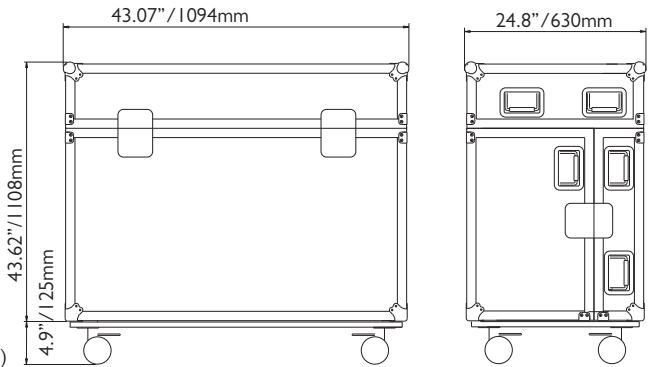
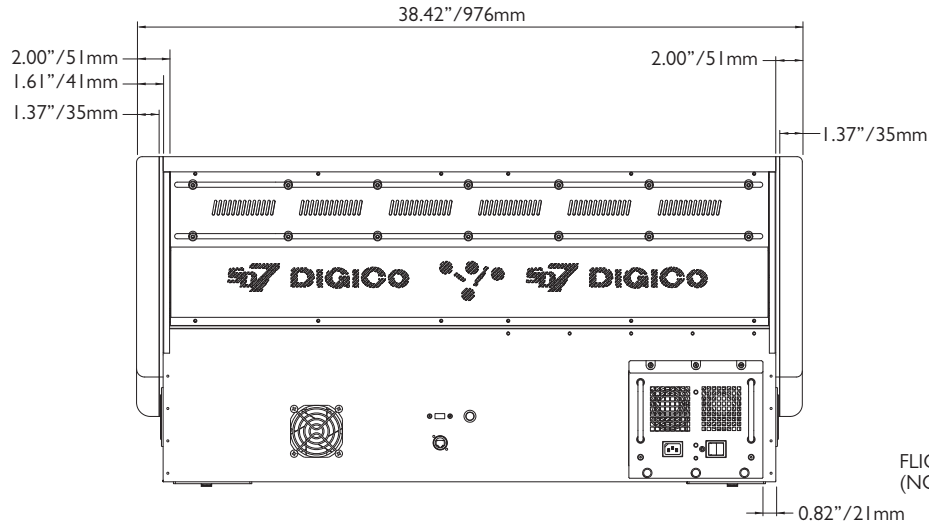
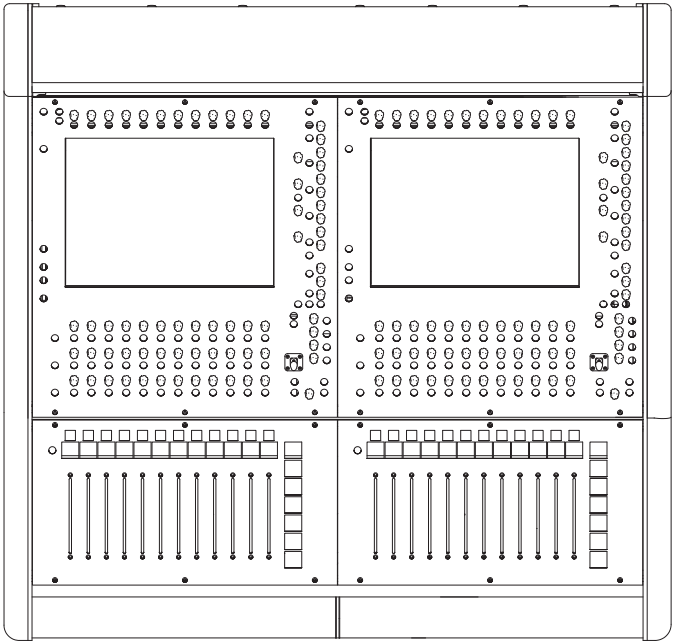
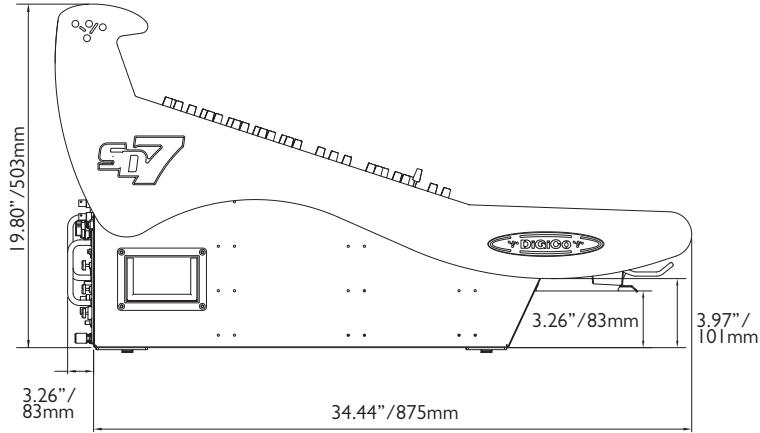

FLIGHTCASE
(NOT TO SCALE)

Products offered for sale may differ from those described or illustrated in this brochure due to later production changes in specifications, components or place of manufacture. The contents of this brochure are therefore not to be treated as representations as to the current availability of products as described, or as to products actually offered for sale. DiGiCo UK Limited reserves the right to make any changes at any time, without notice, in prices, colours, materials, specifications and models, and also to discontinue models. E&OE.