

Hera

User Manual





APEX NV

Schoebroekstraat 62
3583 Beringen (Paal)
BELGIUM

Tel: + 32 (0)11 28 61 91
Fax: + 32 (0)11 25 56 38
e-mail: info@apex-audio.eu
website: www.apex-audio.eu

Trademarks

The APEX trademark is owned by APEX N.V. All other brand, product and company names and any other registered names or trade marks mentioned in this manual belong to their respective owners.

Disclaimer

APEX N.V. has taken all possible steps to ensure that the information given here is both correct and complete. In no event can APEX accept any liability or responsibility for any loss or damage to the owner of the equipment, any third party, or any equipment which may result from use of this manual or the equipment which it describes.

The information provided in this document may be modified at any time without prior warning. Specifications and appearance may differ from those listed and illustrated. Any complaint against APEX N.V. shall be governed by the laws of Belgium.

July 2011

Serial number of this product:

Important safety instructions

CAUTION: to reduce the risk of electric shock, do not remove cover (or back). No user-serviceable parts inside. Refer servicing to qualified service personnel.



The lightning flash with arrowhead symbol, within equilateral triangle, is intended to alert the user to the presence of uninsulated "dangerous voltage" within the product's enclosure that may be of sufficient magnitude to constitute a risk of electric shock to persons.



The exclamation point within an equilateral triangle is intended to alert the user to the presence of important operating and maintenance (servicing) instructions in the literature accompanying the appliance.

Instructions

Before installing or operating the equipment, read all safety instructions, warnings and operating instructions. Heed all warnings. Follow all instructions. Keep all safety, installing and operating instructions for future reference.

Installing and operating location

Do not use this apparatus near water. Do not expose this apparatus to drips or splashes. Do not place any objects filled with liquids, such as vases, on the apparatus.

Do not install near any heat sources such as radiators, heat registers, stoves, or other apparatus (including amplifiers) that produce heat. No naked flames, such as lighted candles, should be placed on the apparatus.

Do not install the apparatus in a confined space such as a book case or similar unit. Do not block any ventilation openings.

Ensure that foreign objects and liquids cannot get into the equipment.

Install in accordance with the manufacturer's instructions. Only use attachments/accessories specified by the manufacturer.

Use only with the cart, stand, tripod, bracket or table specified by the manufacturer, or sold with the apparatus.



When a cart is used, use caution when moving the cart/apparatus combination to avoid injury from tip over.

The apparatus should be located close enough to the AC outlet so that you can easily grasp the power cord plug at any time.

The mains plug, the appliance coupler or the mains switch is used as the disconnect device. Either device shall remain readily operable when the apparatus is installed or used.

Power source and grounding

This product should be operated only from the power source indicated on the apparatus or in the operating instructions. If you are not sure of the type of power supply to your home, consult your product dealer or local power company.

Do not defeat the safety purpose of the polarised or grounding-type plug. A polarised plug has two blades with one wider than the other. A grounding type plug has two blades and a third grounding prong. The wide blade or the third prong is provided for your safety. If the provided plug does not fit into your outlet, consult an electrician for replacement of the obsolete outlet.

Connect Class I construction apparatus to an AC outlet with a protective grounding connection.

Do not overload wall outlets, extension cords or integral convenience receptacles, as this can result in a risk of fire or electric shock.

Protect the power cord from being walked on or pinched, particularly at plugs, convenience receptacles and the point where they exit from the apparatus.

Unplug this apparatus during lightning storms or when unused for long periods of time.

Batteries (battery pack or batteries installed) should not be exposed to excessive heat such as sunshine, fire or the like. Never dispose of batteries in a fire as they may explode and cause injury.

CAUTION: Danger of explosion if battery is incorrectly replaced. Replace only with the same or equivalent type.

Cleaning, maintenance and servicing

Unplug the apparatus from the wall outlet before cleaning. Do not use liquid cleaners or aerosol cleaners. Use a damp cloth for cleaning.

Do not attempt to service this product yourself, as opening or removing covers may expose you to dangerous voltage or other hazards. Refer all servicing to qualified service personnel.

Service is required when the apparatus has been damaged in any way, such as power-supply cord or plug damaged, liquid has been spilled or objects have fallen into the apparatus, the apparatus has been exposed to rain or moisture, does not operate normally or has been dropped.

Intended use

The equipment may only be used for the purpose described in the operation instructions. Never carry out any work on the equipment other than as specified in the operating manual.

Never push objects of any kind into this product through openings, as they may touch dangerous voltage points or short-cut parts, which could result in a fire or electric shock.

Children should never use the apparatus without close adult supervision.

WARNING: excessive sound pressure levels can cause hearing loss.

Environmental precaution

Electrical and electronic equipment may contain hazardous substances for humans and their environment.



The “crossed out wheelee bin” symbol present on the device and represented above is there to remind one of the obligation of selective collection of waste. This label is applied to various products to indicate that the product is not to be thrown away as unsorted municipal waste. At the end of life, dispose of this product by returning it to the point of sale or to your local municipal collection point for recycling of electric and electronic devices.

Customer participation is important to minimize the potential effects on the environment and human health that can result from hazardous substances that may be contained in this product.



Please, dispose of this product and its packaging in accordance with local and national disposal regulations including those governing the recovery and recycling of waste electrical and electronic equipment. Contact your local waste administration, waste collection company or dealer.

Table of contents

Registration	7
Introduction	8
Product highlights	8
Foreword	8
Before you get started	9
About this manual	9
Inspection and unpacking	9
Operating environment	9
Power requirements	9
Installation	9
Front and rear panel description	10
Front panel	10
Rear panel	11
Wiring the unit	12
Connecting the Hera when used as a stand-alone device	12
Connection when the Hera is used together with the Argos	12
Connecting relays to the Hera	13
Connection with a PC	14
Connection with the Apex Leto	14
Principles of operation	15
Turning on	15
Standard operations	15
Threshold scheduling	17
Logic outputs	17
Additional functions when used with the Argos	18
Microphone distance compensation	18
Installer menu	19
Installer menu	19
Menu structure	19
Basic set-up	21
Operation set-up	22
Logging set-up	23
Preferences	24
To exit	24
Memory readout	25
Technical specifications	26
Limited warranty	27

Register your product

Please take the time to register your product on-line by typing the following URL in your browser:

<http://productregistration.apex-audio.eu/>

As well as registering the product on-line, please take the trouble to record the serial number of the unit in the space provided on page 3 of the manual, and keep the manual in a safe place.

Dear customer,

Thank you for buying the Apex Hera.

Hera is a microprocessor based sound level controller. Hera can be used either as a standalone unit or combined with the Apex Argos. Applications include noise level control in bar, theatre, concert venue,... as well as compliance with Directive 2003/10/EC "Noise at work".

Product highlights

- Factory calibrated for accurate measurement
- All settings may be made from the front panel and are pin-code protected
- Two separated logic outputs for controlling external devices and mains power cut relays, all set/reset times are adjustable
- Average and peak RMS sound level logging over an user adjustable time frame
- System tamper detection and logging
- 14-days sound level log (when measurements are logged at 15 minute intervals)
- Ability to schedule multiple threshold parameters covering any time or day of the week
- Easy computer log read-out through standard serial port
- Optional remote large level display

Hera also offers two logic outputs that may be used to control external devices or mains cut-off if a certain threshold is being exceeded. This threshold value may be scheduled to allow for different sound levels at set times.

All settings are pin code protected and can easily be set from the devices' front panel.

Apex Hera is delivered with a measurement microphone and this is factory calibrated for perfect accuracy.

Hera also offers an automatic calibration function for remote microphone distance compensation. This is imperative in most venues, since the measurement microphones should be placed out of reach.

Optionally you can connect the Apex Leto large deported display to the Hera so that the audience, band or DJ may have visual sight on the sound pressure levels at any time.

The Hera may be used together with the Apex Argos. The Argos will then be slaved onto the Hera's measurement and threshold.

Foreword

Hera offers sound level monitoring and logging of events. As a standalone unit it can be used as a cut-off device, as is required by some authorities. Combined with the Argos the combined units will act as a sound level controller with measurement and logging function.

Hera, will not only log the average and peak RMS sound level pressure over a time period, but Hera will also detect and log the attempts of system tampering (for example disconnection of the microphone). The logs can be easily consulted by any user directly from the front panel or retrieved on a computer and printed out.

Use the Hera together with the Apex Argos, they will be your neighbours dream team !

About this manual

Carefully read all instructions and warnings before operating this appliance. Keep this manual in a safe place so that it can be referred to when required.

This manual describes Hera internal software version v2.2.

Latest manual revision can be downloaded from:
<http://www.apex-audio.be/manufacturing/support/downloads/>

Inspection and unpacking

Box content:

- **Hera unit**
- **factory calibrated microphone**
- **IEC AC power cable with mains plug**
- **multi-conductor D-sub 15 data cable for use with Argos**
- **Terminal block 4-way for logic outputs**
- **this manual**

Operating environment

This appliance is designed to operate in most normal climates, at a temperature between 0 °C and 50 °C (32 - 122 °F), with relative humidity between 10% and 60%.

Power requirements

BEFORE you connect any unit to the mains, please make sure that the voltage of your local AC supply is within the acceptable range of the unit.

The Hera is designed to work from an AC supply between 90V and 240 V, at a frequency between 50 and 60 Hz. No AC voltage selector is provided as the device automatically adjusts to the incoming AC voltage.

Precautions should be taken so that the appliance is properly grounded at all times. **This unit must be earthed.**

Installation

If the unit is brought into a warm room from a cold environment, internal condensation may occur. Ensure that the unit has been allowed to reach ambient temperature before switching it on.

Although this unit is intended for installation in a standard 19-inch rack it can nevertheless be used freestanding. If the unit is installed in a flight-case or in an equipment rack, fix the unit with all four screws through the front panel holes. For normal use no extra support is needed, but in more extreme conditions, such as on the road, we recommend the unit is supported at the rear.

Allow at least 10 cm (4 inches) at each side of the unit for sufficient ventilation.

Front panel

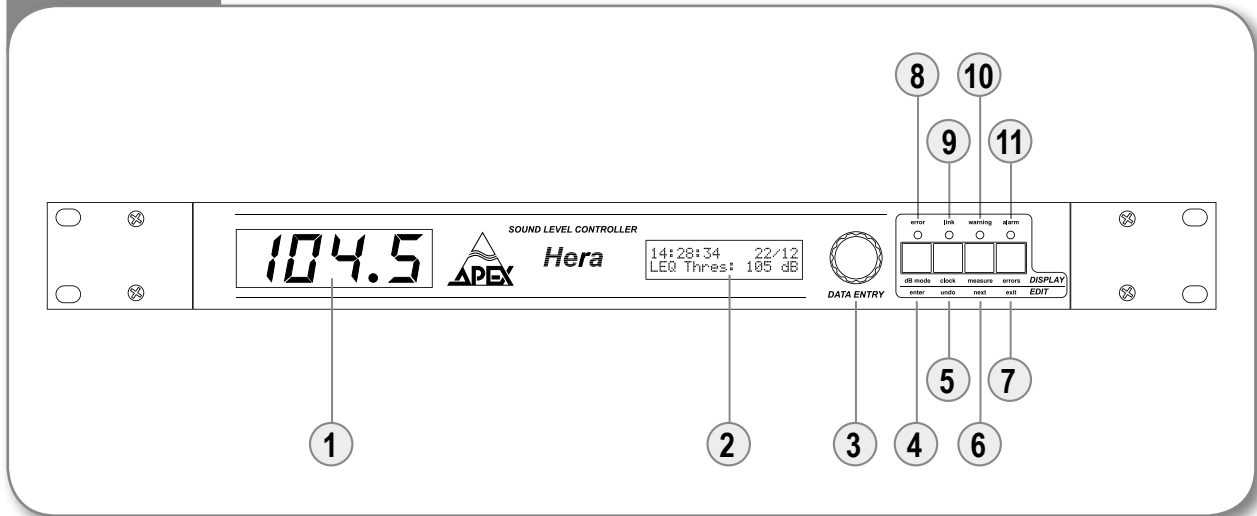

Front panel

- ① **LED display**
RMS, LEQ, MAX,... sound level display
- ② **LCD display**
This display is used in conjunction with the rotary encoder and the pushbuttons. It shows settings, adjustments and provides a readout of control-data.
- ③ **Rotary Encoder**
Used to change settings and to navigate through menus and lists.
- ④ **dB Mode/enter** push button
- ⑤ **Clock/undo** push button
- ⑥ **Measure/next** push button
- ⑦ **Errors/exit** push button
- ⑧ **Error** red LED indicates any system tampering or failure. Consult the error log to know the origin of the error.
- ⑨ **Link** green LED indicates a proper connection with the Apex Argos.
- ⑩ **Warning** yellow LED indicates the warning relay output is activated.
- ⑪ **Alarm** red LED indicates the alarm relay output is activated.

Rear panel

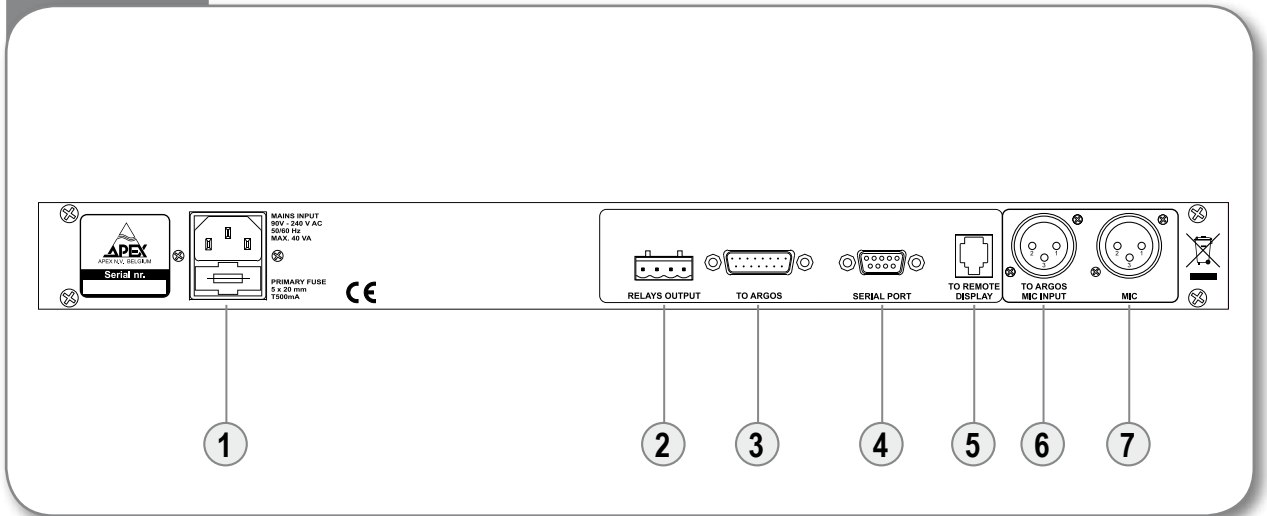

Rear panel

① AC connector and fuse

② Relays output

WARNING: under no circumstances should mains AC voltage be plugged into these outputs.

The connections are (seen from left to right): ground, power cut relay, warning relay, + 12 Vdc.

For an example of how to connect the relay outputs, see "Wiring the unit" in the next pages.

③ To Argos

This connector must ONLY be used for connection with the Apex Argos.

④ Serial port

Enables connection with an external computer in order to read the Hera's memory.

⑤ To remote display

This connector allows on or more Leto deported display to be connected. Leto will mimic the information shown on the front-panel LED display (1).

⑥ To Argos Mic input

This connector must ONLY used for connection with the Argos.

⑦ Microphone input

Connect here the microphone SUPPLIED WITH THE Hera.

CONNECTING THE HERA WHEN USED AS A STAND-ALONE DEVICE

Connect the microphone supplied with the Hera to the microphone input located on the rear panel (see rear panel drawing). In the installer menu, the operation mode must be set in 'standalone'. Refer to the section "installer menu" for details.

CONNECTION WHEN THE HERA IS USED TOGETHER WITH THE ARGOS

Connecting the Hera to the Argos

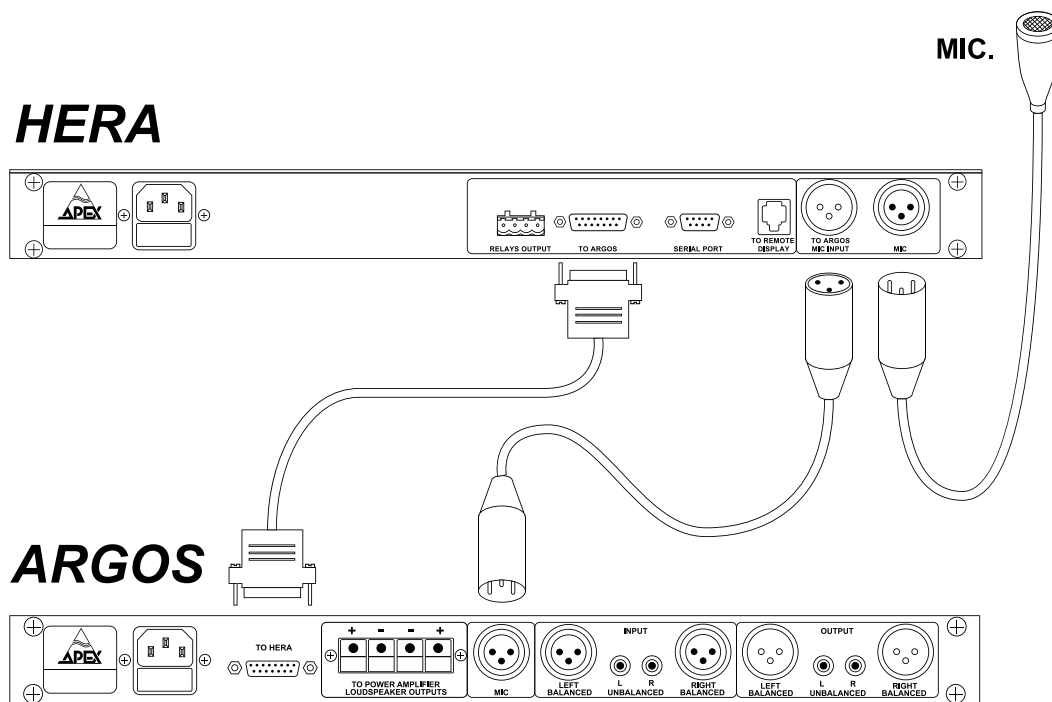

Connect the microphone supplied with the Hera to the microphone input socket located on the rear panel of the Hera. Connect an XLR cable from the connector marked 'To Argos MIC INPUT' on the Hera to the microphone input on the Argos. Connect the data cable to the 'TO Argos' socket on the Hera to the connector marked 'TO Hera' on the Argos.

The data cable is type DB15 male to DB15 female cable pin to pin in direct numbering sequence (1 to 1, 2 to 2, and so on up to 15). The XLR cable should be connected in the same manner. Be very careful **NOT TO CONNECT** the earth to the chassis and definitely be especially careful not to make any solder links between pin 1 and the metal chassis of the socket.

The wiring protocol is 1 = GROUND, 2 = HOT, 3 = COLD.

CAUTION: Because of wide tolerances in microphone manufacture and the need to obtain an exact sound pressure level reading, the microphone delivered with the Hera and the Hera itself are a complementary pair, i.e. they are calibrated together at the factory.

ALWAYS USE THE MICROPHONE SUPPLIED WITH THE HERA !

The Hera must be set in 'Argos attached' operation mode. Refer to the section "installer menu" for details.

The Argos must be set up as follows:

- 'Source' switch in 'micro' position;
- the setting of the THRESHOLD potentiometer is not important because the threshold is fully controlled by the Hera;
- 'Speed' switch on 'slow';
- 'Noise' switch on 'OFF'.
- For the 'Hold' switch, choose the setting most appropriate for your application (see the Argos manual for more information).

Relays can be connected using the connector labelled 'RELAY OUTPUTS'. Only use 12V DC relays. No external power supply is required, so do not connect any form of power to the Hera's relay outputs.

The different signals available at the connector are :

Pin 1	Pin 2	Pin 3	Pin 4
Ground	POWER CUT relay	WARNING relay	+12 V dc

This numbering is arranged looking at the rear panel, from left to right.

CONNECTING RELAYS TO THE HERA

Hera has two open-collector logic outputs. The first is for signalling (warning output) that the sound level threshold has been exceeded and the second usually to shut off the electrical power (alarm/cut-off output) if the sound level has not been reduced after the warning.

As these outputs are open-collector outputs, they can be used to provide control over two external relays or also be used to drive logic systems such as Programmable Logic Controller (PLC) in industrial environments.

Connecting relays to the Hera

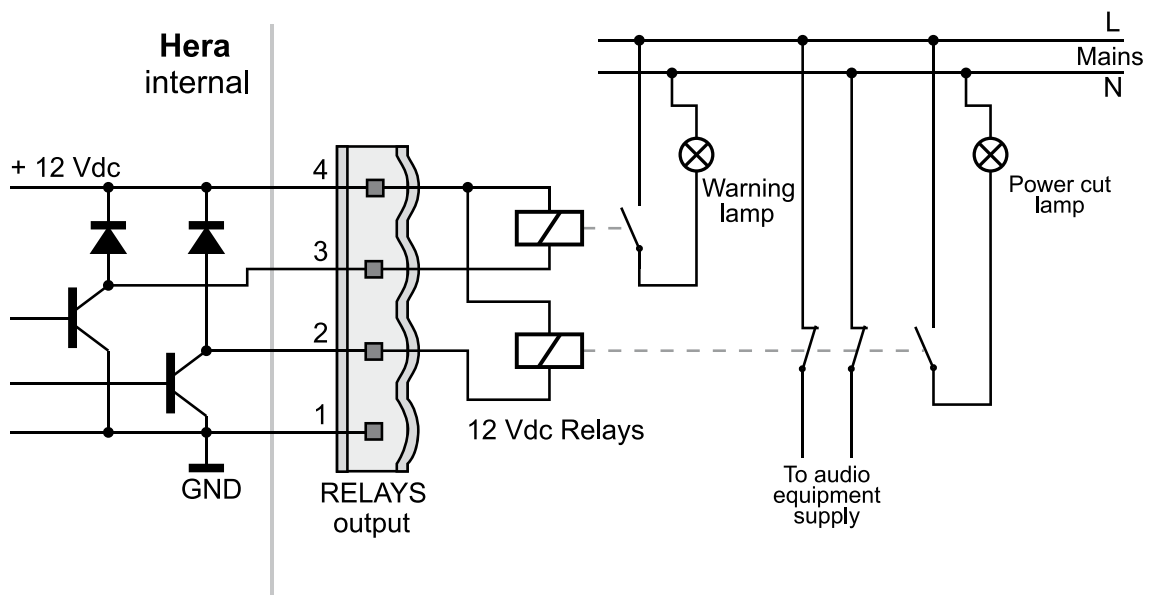

WARNINGS:

1. Hera relay outputs are current limited to 60mA. Some electromechanical relays or contactors may require larger pull-in current to be activated. In such situation, a smaller relay, requiring less pull-in current shall be wired between the Hera and the contactor. **We recommend the use of solid-state relays which require very small pull-in and holding currents.**
2. Under no circumstances should mains AC voltage be plugged into these outputs !

CONNECTION WITH A PC

Connection to a PC allows data stored in the Hera's memory to be recovered. The connection is made using a RS-232 serial port on the PC.

Depending on the hardware revision of your Hera, you will be able to use a standard straight serial cable or you will need to make one by yourself.

Hera's manufactured from March 2008 have a female 9-pin D-Sub connector for serial connection. With those Hera, you can use a standard pin-to-pin serial male / female cable.

Older devices have a male 9-pin D-Sub connector and require a costume made cable. It requires a 3 conductor cable with a female 9-pin D-Sub connector on both end, wired as follow:

Hera side		PC side
Sub-D 9 female		Sub-D 9 female
pin 1	ground	pin 5
pin 3	data	pin 3
pin 4	data	pin 2

COMMENTS:

1. This cable is specially for the Apex Hera and therefore cannot be found in any computer shop.
2. This cable is not reversible. One side is for the Hera and the other for the PC. Connect the Hera side into the Hera serial port (see rear panel diagram) and the PC side into an unused RS-232 port on the PC.

Most of today's PC and laptop don't have a serial port. Nevertheless inexpensive USB to RS-232 converters are available in any computer shop.

It is also possible to interconnect the Hera with a PC using Ethernet network. A whitepaper detailing this topic is available on the Apex website.

CONNECTION WITH THE APEX LETO

The Leto large display provides a copy of the LED sound level display of the Hera for use at a remote location.

The optional Leto display is connected to Hera using a supplied RJ-12 cable. This cable length is limited to just a few meters (see the Leto user manual for more information). If longer distances between Leto and Hera are required, then the optional Leto Extender kit can be purchased.

Using the Extender kit enables cable lengths up to 200 m to be used. The kit consists of one transmitter and one receiver unit and standard RJ-45 FTP network cable should be used to connect the two together (cable not supplied). Be aware that this signal does not conform in any way to Ethernet standards !

A maximum of two Leto displays may be slaved to the Hera by daisy-chaining two receiver units together.

Connecting Leto and Extenders

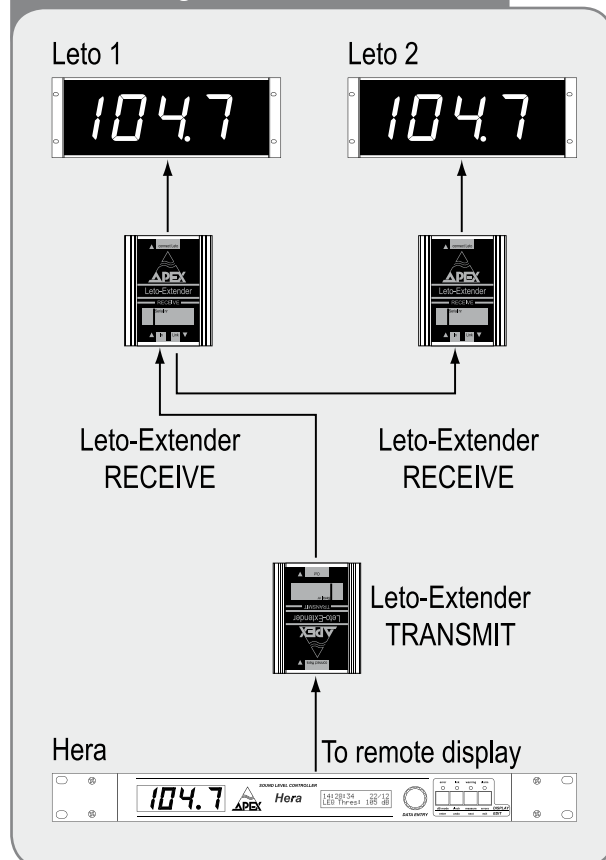

TURNING ON

Hera does not have an on/off switch. It lights up when the AC power is connected. At boot-up, the LCD screen will briefly display the unit's firmware version. Contact an Apex-approved dealer for any software updates which may become available.

STANDARD OPERATIONS

The LED indicator on the left side of the front panel displays the sound pressure level in dBspl. This can be pre-selected to show present, average or maximum value as follow.

RMS:	present level
LEQf (fast):	average value over 10 seconds
LEQn (normal):	average value over 1 minute
LEQu (user):	average value installer adjustable period
MAX:	the peak value

The LED display mode is changed by pressing the 'dB mode' button. The selection is shown on the LCD display when in 'clock' mode.

In case the Leto deported display is used, it will mimic the LED display.

COMMENT: if the sound pressure level falls below the minimum measurable (55 dB) then the display will show 4 horizontal bars '----'.

The LCD screen in the middle of the front panel has three different display modes:

- 'clock' mode
- 'measure' mode
- 'error' mode

These three modes are selected by pressing one of the three switches labelled 'clock' 'measure' and 'error.' See below for details about each mode.

Messages on this display can be in English, French, Dutch or German. Language selection is made from the installer menu.

The 4 LEDs located just above the push buttons have the following functions:

- **Red LED error:** lights in the event of any fault. This could, for example, come from the seal of the Argos. If this happens, the message will be stored in the list of errors (cf. 'error' mode). The LED will go out a few seconds after the problem disappears.
- **Green LED link:** when the Hera is properly connected to an Argos, this LED shows that the connection is good. It should be lit up at all times when the Argos is in use.
- **Yellow LED warning:** lights when the 'alert' relay is triggered. This LED only functions when the Hera is used in stand-alone mode.
- **Red LED alarm:** lights when the 'cut' relay is triggered. This LED only functions when the Hera is used in stand-alone mode.

LCD IN CLOCK MODE

This is the normal operation mode. In this case, the displays will look something like this :



```
08:55:47  07/12
RMS Thres:90 dB
```

In the left upper corner you find the actual time displayed in the following format: HH:MM:SS. In the right upper corner, the date will be displayed in the following format: DD/MM. The second line indicates the LED display MODE (RMS, LEQf, MAX, ...), followed by the actual threshold indicated in dBspl. Above this threshold level, the Argos will begin to reduce the signal. In case the logic outputs are enabled and if the equivalent continuous sound level (LEQ) over adjustable period of time exceeds the threshold, the logic outputs will be triggered. The threshold can be adjusted from the installer menu.

In this mode the Data Encoder knob allows the LCD back-lighting to be adjusted.

LCD IN MEASUREMENT LIST MODE

```
At: 08:53 07/12
LEQ: 97 MAX: 97
```

Hera stores a record of the **equivalent continuous level (LEQ) and maximum sound pressure** level over a user adjustable period of time into its memory. The memory can contain up to 1440 items. When the memory is filled, the newest measurement will replace the oldest. The time interval between each item of this list is adjustable in the installer menu. Interval can be from 1 minute to 8 hours. By default, the interval between each record is of 15 minutes, giving a total memory of 15 days.

When the LCD display is in 'measurement list mode', you can inspect all records stored in the memory. Turn the 'Data Encoder' knob to view the different measurements.

LCD IN ERROR LIST MODE

```
At: 23:03 19/11
Micro Disconnect
```

Hera can also detect if anyone has disconnected any cables from it, or even if anyone has opened the lid which prevents access to the Argos adjustment. Should any of these events take place it is automatically stored in the list of errors and events. This list, as the record of sound pressure levels, can be inspected at any time by the user and can even be transferred to a computer. It is thus extremely easy to see if anyone has tried to cheat !

Turning the rotary encoder allows the operator to scroll through any errors and events taking place in the system, showing the date and time at which they occurred.

If the system generates an error, the 'error' LED (see the front panel) illuminates. This error is instantly recorded in the error list. The LED extinguishes when the problem disappears.

The list of messages, and their meaning, can be found here:

Message	Meaning
Log Started	Commencement of recording of errors and events.
Power Switch ON	Hera started up.
Power Switch OFF	Hera shut down.
Micro Disconnect	Microphone disconnected from Hera.
Micro Connected	Microphone connected to Hera.
Argos SealRemove	The lid giving access to the Argos calibration facilities has been opened.
Argos Seal OK	The lid giving access to the Argos calibration is in its proper place.
Argos Disconnect	Data cable between the Argos and the Hera disconnected.
Argos Connected	The Argos is connected to the Hera.
Argos Mic. Discon	The XLR cable between the Argos and the Hera has been disconnected.
Argos Mic. Conn.	The XLR cable is connected.
Clip Detection	Argos VCA (level reducing device) overloaded.
Installer setting	The Hera adjustment has been modified by the installer.
Warning Relay ON	The 'Alert' output relay has been activated.
Alarm Relay ON	The 'Cut' output relay has been activated.
Warn. Relay OFF	The 'Warning' relay output have been deactivated.
Alarm Relay OFF	The 'Alarm' relay output have been deactivated.
Warn. Relay Disc	The 'Warning' relay has been disconnected.
Alarm Relay Disc	The 'Alarm' relay has been disconnected.
In Stand alone	Hera has been configured to work in stand-alone mode, but will detect if an Argos has been connected.
Transmis. Start	Data transmission to the PC has begun.
Transmis. End	Data transmission to the PC has been completed.

THRESHOLD SCHEDULLING

The threshold can be constant or be scheduled over 4 periods per week days. Threshold scheduling allows for automatic adjustment of the sound level over the time. For example, it is possible to automatically set a different threshold during the working hours, the evening and nights. Or even during week's nights and weekend's nights.

Threshold setup is done through the installer menu.

LOGIC OUTPUTS

The first logic output, called warning output, is usually used for signalling that the sound level threshold has been exceeded and the second, called alarm or cut-off output, usually to shuts off the electrical power if the sound level has not been reduced after the warning.

NOTE: the logic outputs must be enabled from the installer menu.

Logic outputs are triggered if the equivalent continuous sound level (LEQ) over a user adjustable period of time exceeds the threshold. In the installer menu, installers have the ability to setup three time periods as follow:

- **Warning time period:** if the LEQ value over this period exceeds the actual threshold, the first logic output is triggered.

- **Cut-off time period:** if despite the warning the LEQ value over this period exceeds the actual threshold, the second logic output is triggered.

- **Recover-after time period:** if the LEQ value over this period is under the actual threshold, both warning and cut-off outputs are resettled. The recovering time can also be set in 'manual' so that only an operator knowing the installer menu's pin code can reset the logic outputs.

NOTE: If the microphone is disconnected the warning relay will operate. If the microphone is not reconnected within 10 seconds the alarm relay will activate.

The graph bellow illustrates the principle of operations of the logic outputs. In this example, the threshold has been set to 110 dB, the warning time period to 30 seconds and the cut-off time period to 1 minute.

At the second 70, the music has exceeded the threshold and the warning time period has start counting. The LEQ has been computed over the following 30 seconds but the result was below the threshold. So nothing happened.

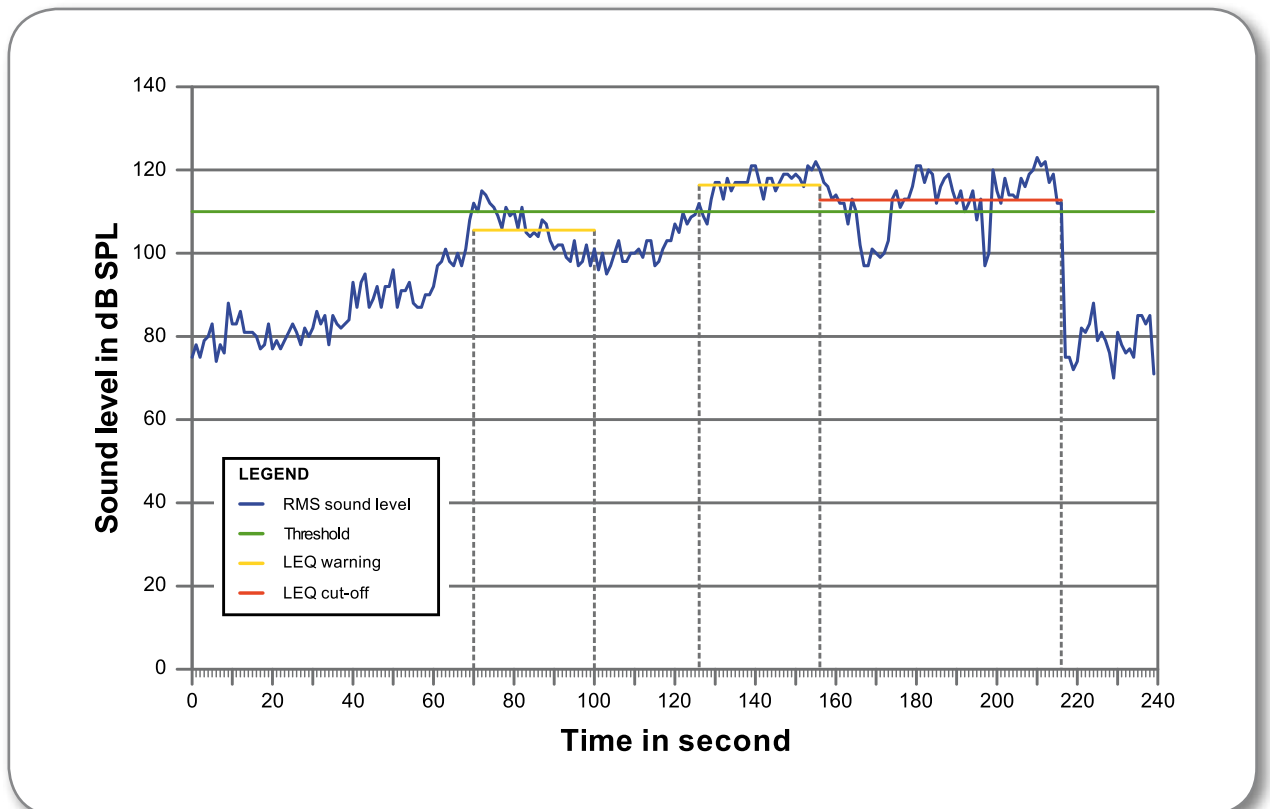

At the second 126, the DJ exceeds the threshold once again, so the averaging before the warning has started. 30 seconds later, the Warning lamp has been switched on because the LEQ value was over the threshold. At that time, the cut-off time period starts counting.

The DJ has seen the warning and has directly reduced the level, but unfortunately a few seconds later, he pushed the volume up again. As the result that 1 minute after, the LEQ value was still higher than the threshold and the cut-off relay has been activated, cutting-out the electricity on the power amplifier.

ADDITIONAL FUNCTIONS WHEN USED WITH THE ARGOS

When connected to the Argos limiter, the Hera measures the microphone signal and sends the appropriate commands to the Argos, which can then reduce the sound pressure level if necessary.

The Hera can also control the pink noise generator in the Argos. Pink noise is used as a reference for calibrating the Hera should it be necessary to take into account differences in sound pressure level between the actual position of the microphone and the position at which the authorities measure.

MICROPHONE DISTANCE COMPENSATION

The measurement microphone is often located where it cannot be interfered with. Consequently there is a good chance that the sound pressure level at the microphone will be different from that on the dance floor, which is where the authorities take their level measurements. To get round this problem the Hera can calculate the difference and factor it into its measurements. The calibration procedure is fully described in the "installer menu" section.

INSTALLER MENU

The installer menu allows the Hera to be set up and adjusted for optimum performance. To access the installer menu simply press and then release the 'enter' and 'next' buttons on the front panel at the same time. The Hera then asks you to enter your secret code (PIN number). **The default code is 1234.**

You can change the number under the cursor using the rotary encoder. To go to the next number, press 'enter'. To go back to the preceding number, press 'undo'. When the four numbers have been entered press 'enter' again to go into the menu.

NOTE: We strongly recommend that you change the PIN number immediately to a code number of your choice (option 11 in the menu). Do not write this code down and do not leave it where the end user can find it !

MENU STRUCTURE

The following diagram shows the complete menu structure. To move down the page, use the rotary encoder. To move across the page, press 'enter' to go to the right and 'undo' to go to the left.

The following chapters describe each of the menu options in detail.

HERA installer menu overview

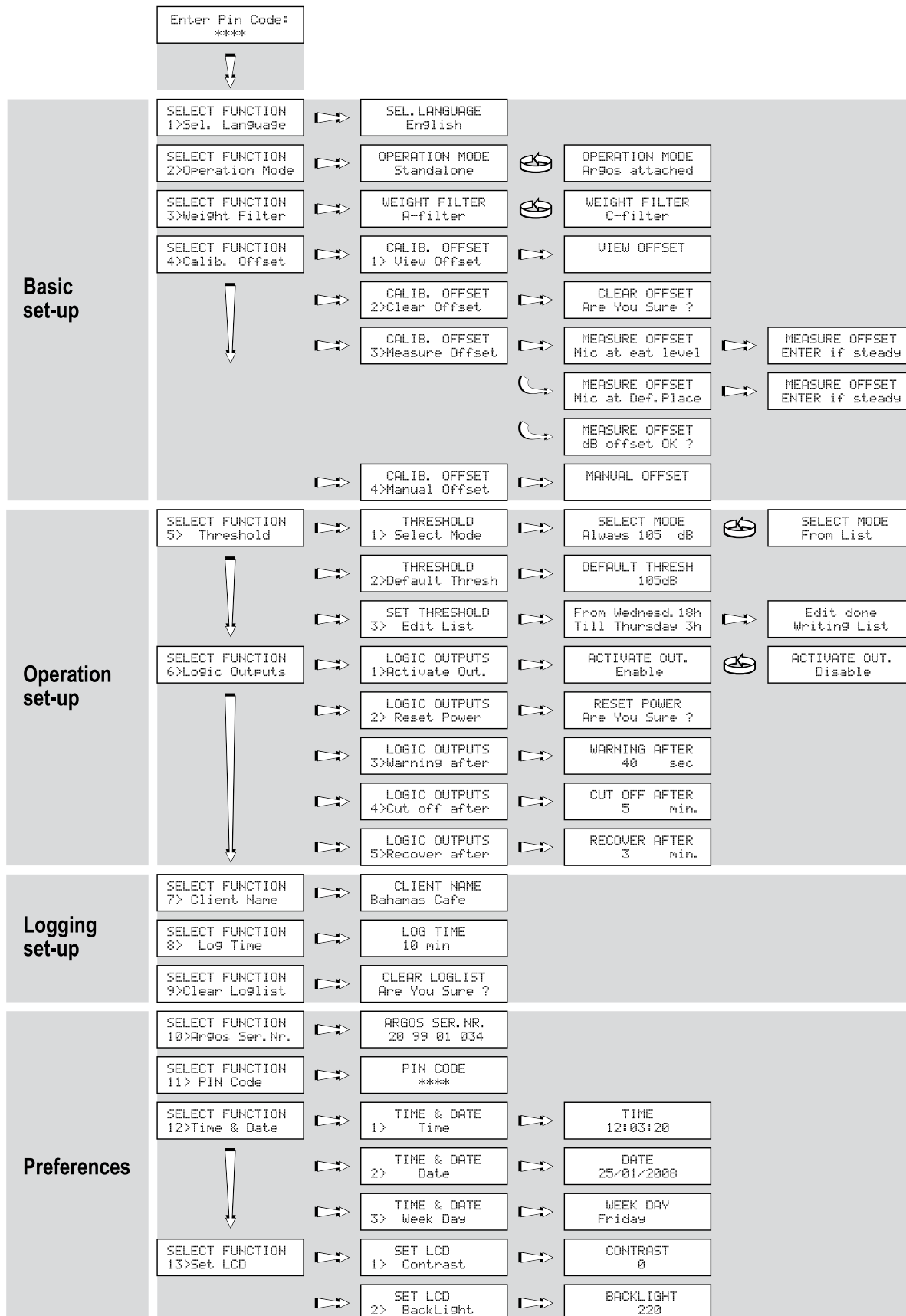

BASIC SET-UP

OPTION 1: Choice of language

This option allows you to choose the language in which messages will be displayed. All types of messages are affected, including both error/event list and measurement list. The available languages are English, Dutch, German and French.

Press 'enter', select the desired language using the rotary encoder and then push 'enter' again to store your choice.

OPTION 2: Choice of operational mode

This option allows you to choose between operating the Hera as a stand-alone device or in connection with the Apex Argos limiter. **This option is vital for the proper functioning of the Hera. If this option is not set up correctly, the Hera will definitely generate error messages.**

Press 'enter', turn the encoder to select either 'Hera only' or 'with Argos' and press 'enter' again to confirm your selection.

OPTION 3: Frequency weighting filter

With this option, you can choose which frequency weighting filter is applied to the measurement. Choices are A-filter or C-filter. The default is A-filter as it is the most commonly used filter curve.

IMPORTANT NOTICE: If the Hera is used together with an Argos, you need to change the weighting filter of the Argos as well. This can be done by changing the position of a jumper inside the Argos. Argos is by default always set on A-filter. Please refer to the Argos user manual for detailed information.

OPTION 4: Microphone position compensation

The measuring microphone is normally installed somewhere where it cannot easily be reached, to prevent it from being covered. However there is likely to be a difference in sound pressure level between the microphone point and – for example - the dance floor. This procedure allows you to calculate this difference so that the Hera can compensate for it in its measurements.

Positional compensation allows level differences between the actual position of the microphone and the place where sound pressure level is tested (by the authorities) to be taken into account.

OPTION 4.1: Viewing compensation setting

This option simply shows the actual compensation in decibel on the LED display.

OPTION 4.2: Erasing the compensation setting

This option is used to erase the compensation setting and to return to direct measurement of sound at the microphone position. Press 'enter' to confirm and 'undo' to cancel.

OPTION 4.3: Measuring the difference

The calibration of positional compensation requires a pink-noise or sinus generator. In case Hera is used together with Argos, no external generator is required. Indeed, the Apex Argos has a built-in pink-noise generator. The Argos' generator will be remotely controlled by the Hera.

If you use a tone generator, we recommend you to use a sinus of a 1 kHz frequency.

COMMENT: Hera and its microphone are **calibrated together at the factory** and are a pair. If you install a Hera and an Argos together, **ONLY USE THE MICROPHONE SUPPLIED WITH THE HERA.**

To calibrate the Hera proceed as follows:

- Turn the amplifiers down to their lowest setting.
- Press 'enter'. Hera will ask you to place the measuring microphone at the point where the sound is normally tested (Microphone level at ear), for example in the middle of the dance floor or wherever the authorities normally make their level tests.
- Press 'enter'. If Hera is used together with Argos, it will now supply a pink- noise. If not, the Hera will ask you to supply one. Press 'enter' again when you are ready.
- Slowly raise the amplifier gain to give a level of around 80dB. When the level is stable press 'enter'.
- **Do not touch the amplifier gain until calibration procedure is over !**
- If no Argos is connected. Turn the pink-noise off and press 'enter'.
- Hera then asks you to place the microphone where it will be normally used (definitive microphone placement), for example on the ceiling. When ready press 'enter'.
- The Argos will once again generate pink-noise.Or you will be asked to turn on your external pink-noise generator. Press 'enter' when you are ready.
- Hera will display the level measured, which is likely to be different from the level on the dance floor. When the level has stabilised press 'enter'.
- If no Argos is connected. Turn the pink-noise off and press 'enter'.
- The Hera will display the level difference between the two positions and will ask you to accept by pressing 'enter' or to reject by pressing 'undo'

COMMENTS: pressing the 'undo' switch allows you to return at any time to the previous setting or to cancel the operation.

If you use Hera together with Argos and you don't hear any noise, please make sure to set the correct operation mode in option 2.

If you use an external tone or pink-noise generator, be sure to not modify its output level during the calibration procedure.

OPTION 4.4: Manual compensation setting

This option is used to manually enter the compensation. The actual compensation in decibel is shown on the LED display. Turn the rotary encoder to adjust it. Press 'enter' to confirm and 'undo' to cancel.

Adjustment range goes from -20 to +20 dB per tenth of dB step.

OPERATION SET-UP

OPTION 5: Adjust threshold

OPTION 5.1: Selecting threshold mode

The limit threshold can be either constant or can vary following a weekly list.

You can choose between 'Always xxx dB' or 'follow list'. Select by turning the encoder and then pressing 'enter'.

OPTION 5.2: Threshold by default

This option enables you to set the threshold when you have chosen the option 'Always xxx dB'. Select by turning the encoder to the desired value and then press 'enter'.

Adjustment range is from 70 to 110 dB.

OPTION 5.3: Editing the weekly list

The weekly list allows the 7-day week to be sliced into 4 daily time periods, making a total of 28. The threshold can be different for each of these periods. The beginning of one period marks the end of another.

Press 'enter' and the Hera will display the following message:

```
From Monday 3h  
Till Monday 8h
```

This shows the first period, which begins Monday at 3 a.m. and ends at 8 a.m. Using the rotary encoder you can adjust the threshold for this period. This will be shown on the LED display at the left of the Hera front panel.

Only the time shown on the first line can be changed on this screen. It can be changed using the 'next' and 'exit' buttons, 'exit' to increase the time in hourly intervals and 'next' to decrease it by the same amount. The end time, shown on the second line, indicates the start time of the next period. The one period's end time cannot overlap the next period's start time.

To go to the next time period, press 'enter', change the start time using the 'next' and 'exit' buttons and change the threshold using the rotary encoder.

To go back to the preceding period press 'undo'.

When the start times for all periods have been set, Hera requires a few moments to store the new list.

OPTION 6: Warning and cut logic outputs

Relay outputs are triggered on time-averaged sound level value. Time-averaged sound level is also called **equivalent continuous sound level (Leq)**. It is nothing more than an averaging of each RMS sample values measured over a certain period of time (each sample being taken every 125 mS). This Leq value is then compared with the actual threshold and relays are switched on or off as explained below.

OPTION 6.1: Enable or disable the logic outputs

This option allows you to enable or to disable the relay outputs.

OPTION 6.2: Reconnecting the AC mains supply

This option resets both relays and thus re-establishes the AC electric supply and switches off the warning lamp. This is the only way to reconnect the AC supply if option 6.5 has been set to 'Manual'.

OPTION 6.3: Warning time-averaged period

This function allows you to set up the time-averaged period before the 'alert relay' signalisation is set. As soon as the actual threshold is exceeded once, this period starts counting and the average sound level is computed. If this average is then higher than the threshold, the 'alert relay' will be switched on and the 'cut' time-averaging begins. If the average is below the threshold, nothing happens.

Adjustment range is from 10 sec to 60 sec by 10 sec steps.

OPTION 6.4: Cut-off time-averaged period

Enables adjustment of the averaging period before the 'cut relay' operates. If the average sound level over this period is higher than the threshold, the 'cut relay' is activated and the AC supply is cut off. If it is lower than the threshold, both 'alert' and 'cut' relays are deactivated.

Adjustment range is from 1 min to 20 min by 1 min steps.

OPTION 6.5: Recover after period

This option is used to configure the averaging period before the AC supply can be recovered. If the equivalent sound level over this period is below the threshold, both 'alert' and 'cut' relay will be resettled. If not, this period starts running again.

By choosing the 'Manual' option you can opt for manual reset. In this case the PIN number must be known to enable access to the installer menu. Option 6.2 should then be used to bring the AC supply back on line.

Adjustment range is from 1 min to 60 min or manual recover.

LOGGING SET-UP

OPTION 7: Client's name

This function allows you to store the client's name in the Hera's memory.

Press 'enter', turn the encoder to select a character and press 'enter' again to go to the next character.

The name must be 16 characters long; all character positions must be filled, either using a letter, number or a space.

OPTION 8: Measurement log time

As explained in the user manual, Hera logs the equivalent level (Leq) and peak level over regular time interval. It is also the time interval between each updating of the level indicated on the Hera's LED display if the LEQu display mode has been chosen by the user.

This option allows this time interval to be adjusted. By default, the value is 15 minutes. Adjustment range is from 1 min to 59 min by 1 min steps and from 1 hour to 8 hours by 1 hour steps.

Hera's memory is large enough to store up 1440 log items. If the values are stored every 15 minutes, the memory will allow a roll-back of the 15 last days. When the memory is full, the oldest record is replaced by the newest one. That's what we call a ring memory.

OPTION 9: Erase logging lists

Enables the error and events list, as well as the measurement list, to be erased. Hera will then ask you to confirm by pressing 'enter' again, or 'undo' to cancel.

PREFERENCES

OPTION 10: Argos serial number

If the Argos is connected to the Hera then its serial number MUST be entered here. This enables the Hera and the Argos to work together correctly.

OPTION 11: Pin number

Enables the secret code which gives access to the installer menu to be changed. WE ADVISE YOU TO CHANGE IT IMMEDIATELY ! Do NOT give the end user the PIN code.

OPTION 12: Date and Time

OPTION 12.1: Changing the time

Press 'enter'. The Hera will display the time in the format HH:MM:SS. This can be adjusted using the rotary encoder and the 'enter' switch, which enables you to go from Hours to Minutes and then Minutes to Seconds. To store, press 'enter'.

OPTION 12.2: Changing the date

Press 'enter'. The Hera will display the date in the format DD/MM/YYYY. This can be adjusted using the rotary encoder and the 'enter' switch, which enables you to go from Day to Month and then Month to Year. To store, press 'enter'.

OPTION 12.3: Day of the week

Press 'enter', turn the rotary encoder to select the weekday and then confirm by pressing 'enter' or cancel by pressing 'undo'.

OPTION 13: Adjusting the LCD display

OPTION 13.1: Adjusting the contrast

Allows the contrast on the LCD screen to be adjusted. Press 'enter', turn the rotary encoder to select the required value and then store by pressing 'enter'.

OPTION 13.2: adjusting the back lighting

Allows adjustment of the back-lighting for the LCD screen. Press 'enter', turn the rotary encoder to select the required value and then store by pressing 'enter'.

TO EXIT

To exit the menu at any time, press 'exit'.

NOTE: We strongly advise you **not to cut off the AC supply when in the installer menu.**

When the installer menu is entered the Hera stops writing into the error and measurement lists until such time as you exit the menu. This explains the appearance of the message 'List error OFF' in the error list. When the AC supply is restored the list will not be re-activated and data will not be written into it !

If this happens for any reason, go back to the installer menu when the AC power is restored and use the 'exit' button to go back to normal operating mode.

MEMORY READOUT

A Hera read-out PC software is available free of charge. It allows for data stored in the Hera's memory to be recovered and eventually imported into any document. It is possible to retrieve the LEQ and MAX measurements list, the events list and other information such as firmware version. These data can be saved to a file or directly be copied and pasted into a spreadsheet or a database.

Connection with a PC can be made using a serial port or USB and even network using the appropriate adapter. Check the section Connection with a PC earlier in this manual for details.

The latest version of the Hera read-out PC application can be downloaded from the Apex website. This software doesn't require any installation.

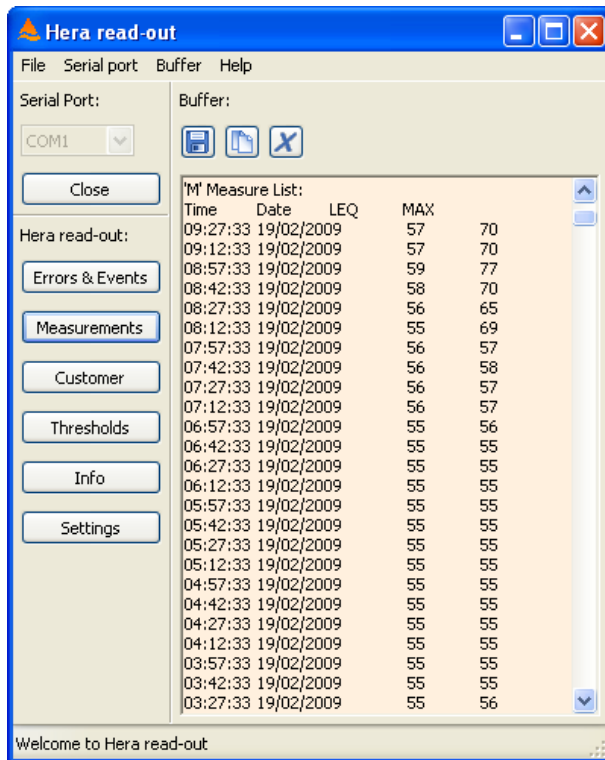

Electrical specifications

Mains requirements

Voltage Auto-detect 90-240 V - 50/60 Hz
 Power consumption 40 VA

Relay outputs

Connections ground, output 1, output 2, +12 V
 Impedance open collector
 Maximum current 60mA maximum for each output

Measurements

Range 55 dBA - 120 dBA
 A-Filter accuracy 27 Hz - 20 kHz + 1.2dB

Mechanical specifications

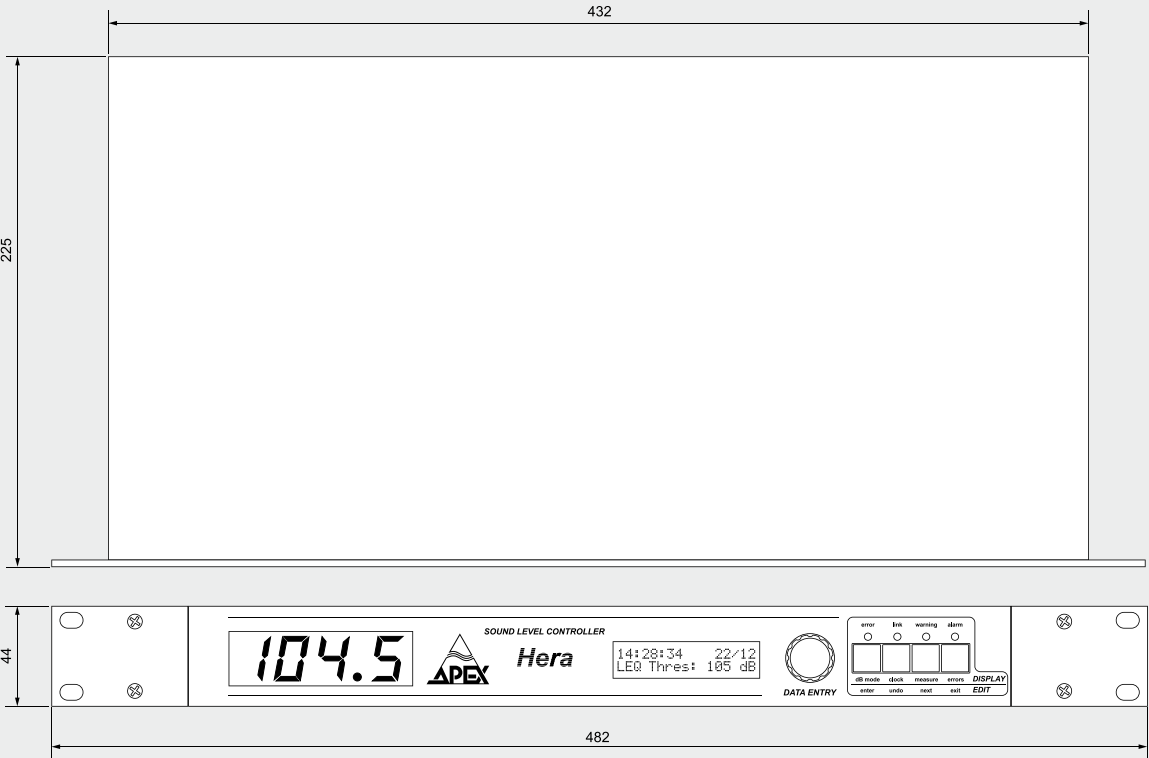

Dimensions

Unit
 Width 482 mm (19-inch)
 Height 44 mm (1U)
 Depth 225 mm

Weight

Unit (Nett) 2,9 kg
 Unit + Package (Shipping) 4,5 kg

In the interest of product development, Apex reserve the right to modify or improve specifications of this product at any time, without prior notice and without any obligation to change or update equipment already delivered.

Limited warranty

Apex N.V. ("Apex") warrants you, the original purchaser, or any party that purchases the device from you, that its products are free from defects in material and workmanship under normal use for a period of two (2) years from the date of original purchase. The date of purchase is the date which appears on the first invoice or any other proof of purchase provided by an Apex approved dealer.

Subject to the conditions and limitations set forth below, Apex will, at its discretion, either repair or replace any part of its products that prove to be defective, provided that the product is returned with proof of purchase, shipping prepaid, to an authorised Apex approved service facility.

Warranty cover of any repairs will only extend to the end of the original warranty period.

We will be happy to provide you with a list of authorised dealers to whom you can return the defective unit or who will give you a returns note to enable you to send the unit to the factory.

Service turn-around time will be as fast as reasonably possible. If you are not satisfied with the repair, contact Apex.

Exclusions and limitations

This limited warranty covers only repair or replacement for defective products manufactured by Apex. Apex is not liable for, and does not cover under warranty, any loss of data or any costs associated with determining the source of system problems or removing, servicing or installing Apex products. This warranty excludes 3rd party software, connected equipment or stored data. Apex does not warrant that the operation of the product will be uninterrupted or error-free. In the event of a claim, Apex's sole obligation shall be replacement of the hardware.

This limited warranty does not cover:

- (1) any damage to this product that results from improper installation, accident, abuse, misuse, natural disaster, insufficient or excessive electrical supply, abnormal mechanical or environmental conditions or other external causes;
- (2) any damage caused by operating the product outside the permitted or intended uses described by Apex;
- (3) any damage caused by any unauthorized disassembly, repair, or modification;
- (4) consumable parts, such as batteries;
- (5) any cosmetic damage.

Apex is not liable for consequential damages.

This limited warranty also does not apply to any product on which the original identification information (including serial number) has been altered, obliterated or removed or any product that has not been handled or packaged correctly.

Warranty services will be furnished only if the product is accompanied by a copy of the original retail dealer's invoice.

Warranty claims other than those indicated above are expressly excluded.

Copyright

© 2000-2011 APEX N.V. All rights reserved. This manual may not be reproduced or transmitted, either in part or as a whole, by any means, be they mechanical or electronic, without the express written permission of APEX N.V.